



**Cott Vending Inc.**

**The Leader in Premium Retailer Brand Beverage Innovation**

**THESE GUIDES ARE FOR MACHINE MODEL: VENDO 821 ONLY**

## **Store Level Vending Responsibilities**

**Two employees at each store should be designated, and trained to operate your retail brand vending machine, to enable them to perform the following:**

- Cleaning the machines, both inside and out, - weekly
- Load the machines correctly with product, - daily
- Empty cash box, - daily
- Report machine malfunctions to Cott (Call 1-800-662-9225, option 1 for service assistance or to diagnose the problem.)
- Perform over the telephone, troubleshooting and diagnostics
- Clear coin jams
- Clear can jams
- Change flavor strips
- Minor part replacement

NOTE: Under the Cott vending program, your employees will be asked to assist in performing over the phone diagnostics, troubleshooting and minor repairs. It is our experience that the vast majority of malfunctions are caused by jammed coins, jammed bottles or cans, store-level electrical problems or cleanliness issues. By partnering with our retailers and their on-site staff, in most cases the malfunctioning machine can be corrected within minutes. In the event that the store staff is unable to correct the problem, Cott will dispatch a contract service company to the store site within two business days.

If parts are necessary, Cott will ship them via UPS to either the store or the contract service company, as appropriate. If parts have been sent to the store for installation by store staff, Cott may request that certain old parts be returned to Cott's Service Center. Cott handles the return of these parts via UPS call tags, at no cost to the store.

The Cott Service Center will automatically contact the store later to verify that the problem has been resolved. The regular service response time frame does not apply to machines damaged by theft or vandalism.

Machines damaged by vandalism should be reported to the Cott Service Center at 1-800-662-9225, option 1 as soon as possible. Please provide as complete a record as possible to help determine the parts and graphic components necessary to repair the machine. Cott will dispatch a service technician to your store to estimate the machine damage and repair the machine if possible.



Cott Vending Inc.

The Leader in Premium Retailer Brand Beverage Innovation

**Coins are falling straight through or getting stuck, & I am unable to purchase a soda. What do I do? Try the steps listed below. If you still have difficulties, call us at (800)662-9225, option 1.**

**It is possible that the coin changer is simply dirty. Since all coins share a common ramp, it gets heavy usage and dirt build-up.**

1. Disconnect power to your machine by unplugging it from the wall or by switching the circuit breaker off at the store's main power panel. *If you cannot reach the plug at the wall, your machine has a main power plug in the lower left corner, inside of the machine with the door open. Please do not touch the fuse near the power plug inside of the machine.*
2. Open the front door of the machine and the inner door. Find the coin changer power cord, located at the top left, rear corner of the coin changer.
3. Follow the power cord to the white plug on its end.
4. Grasp and squeeze the plug and disconnect the socket end.
5. Press down on the plastic coin return lever, at the top of the coin changer. This will cause the front half of the coin acceptor to move toward you. Insert your fingertip between the halves of the acceptor panel on the left side.
6. You should now be able to lift up on the left side of the acceptor gate panel, to expose the inner ramp. The acceptor gate panel is spring loaded at the top right corner. Do not lift the left side more than 90 degrees. (i.e. Do not lift past the point of significant resistance.) Hold the acceptor gate firmly to prevent it from snapping back down.
7. Wipe the exposed inner surfaces on both halves of the acceptor with a damp cloth and MILD soapy water solution. **NEVER USE LUBRICANTS, OIL, OR HARSH CLEANERS WHICH COULD DAMAGE THE COIN CHANGER.**
8. **DO NOT SUBMERGE THE COMPONENTS IN WATER !!**
9. Dry the surfaces and gently release the acceptor gate panel so that it returns to its normal position.
10. Plug the coin changer's main plug back into the white power socket.
11. Close the inner and outer door of the machine. Plug the machine back into the wall, or reset the circuit breaker at the store's main power panel or plug in the power plug in the bottom left corner inside of the machine.
12. Coin test the machine for proper operation.

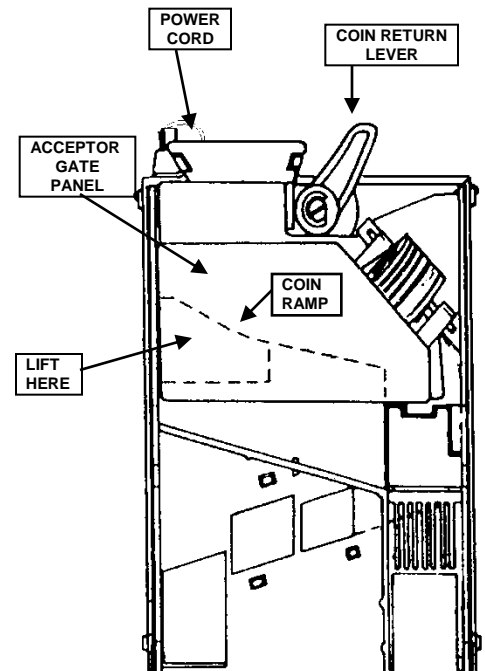

**If the coins are still falling straight through call the Vending Technical Support Center at (800)662-9225, option 1.**



**Cott Vending Inc.**

The Leader in Premium Retailer Brand Beverage Innovation

## How do I get “error codes” from the vending machine for when I call the Technical Support Center at Cott?

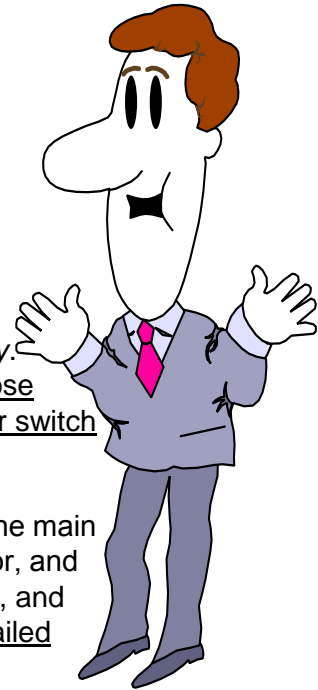

As soon as you open the machine, the unit will show “**Error**” on the digital display if there are errors in the system. If there are no errors in the system, the display will show “**none**”.

If “**Error**” is displayed when opening the door, *press the number two selection button* (second button from the top, on the front of the machine) *while “Error” is on the display.* It is important to remember that the inner and outer doors of the machine must not close against the cabinet where the product is loaded, because there is a plunger style door switch (lower left) that will reset the display if it is pressed.

The display will change to a three or four character code. For examples, “**CHnG**” is the main error code for most coin changer problems, while “**COLJ**” indicates a column jam error, and “**rFrG**” is the main error for refrigeration. *Press the number two selection button again*, and the display will change to a different letter/number code. That second code is the detailed information that Cott Vending needs to understand the problem with the machine.

Using the examples above, if you open the door of the machine and see “**Error**”, and press the number two selection button to see “**CHnG**”, and press the number two selection button again, you may see something like “**CC**” or “**EE**”. If you open the door of the machine and see “**Error**” and then press the number two selection button to see “**COLJ**”, and press the number two selection button again, you may see something like “**CJ01**” indicating a column jam error in column one. If you open the door of the machine and see “**Error**” on the display, and press the number two selection button to see “**rFrG**”, and press the number two selection button again, you may see something like “**CnPr**” or “**SEnS**”. All of those codes are meaningful to the staff at Cott Vending, at 800-662-9225, Option 1.

There may be more than one main error code on your machine. *To back up from the second error code (“CC” or “CJ01” or “CnPr” in the examples) to the main error code (like “CHnG” or “COLJ” or “rFrG”), press the number three selection button (third from the top) on the front of the machine. Then press the number one selection button, and the original main error code may be replaced by another main error code. At that time, you may again repeat the process of pressing the second selection button to get the detail code.*

The following pages may help you correct some of the problems. For example, jammed columns can be cleared by using the page which begins “Bottles or cans are jamming in the column...”

*The final step to clear an error is to press and hold the second selection button for two seconds while that second, detail code (ex. “CC, EE, CJ01, CnPr”) is displayed. Without clearing an error code, it is not possible to easily recover the sales count information from the machine. However, Cott Vending can help you obtain that information through use of the “SALE” mode, and can also determine if a service visit is necessary. Please call Cott at (800)662-9225, option 1, at any time with questions or concerns.*



**Cott Vending Inc.**

The Leader in Premium Retailer Brand Beverage Innovation



## How to Get Sales and Cash Counter Data

As soon as the outer door of the vending machine is opened, the unit will display sales data on the digital readout, if there are no errors in the system. “**CAnS**” will display, followed by a screen with the first numerals of the package count. If the count is greater than 9999, a second screen will appear with the rest of the digits. *For example:* 12345 total packages sold will appear as “**CAnS**” followed by “ 1” and a second screen of “**2345**”.

The package count information will continue to flash on the display for about thirty seconds.\* After that, “**CASH**” will display, along with screens noting the total dollar amount the machine has accumulated. *For example:* \$4321.50 from sold product will appear as “**CASH**” followed by “ 43” followed by “**21.50**” on another screen. Note the placement of the decimal for validation.

\*Please note that if you *press the top selection button* while the unit is displaying “CAnS,” it eliminates the thirty second wait time and advances you immediately to the “CASH” count information.

+++

To access package count data for individual selections, press the second selection button during the “CAnS” or “CASH” display. Press the top selection button to advance forward or backward through the selection numbers on the display. The selections will appear as “SL 1” representing the top selection, or “SL 2” for the second button, and so on, and the unit will then display actual package counts. *For example:* While the unit is showing the original “**CAnS**” on the display, you press the number two selection button and see “**SL 1**” followed by “ 2” followed by “**3456**”, indicating that the top selection button has sold 23456 packages over the life of the machine. If you then press the number one selection button, the unit may display something like “**SL 2**” followed by “ 4” and then “**5678**”, indicating that the second selection on the machine has sold 45678 packages over the life of the life of the machine.

*It is also worth noting that this data, which is displayed when the door is opened, is non-resettable. The data is accumulated over the life of the circuit control board and can only be changed by replacing the control board.*

**Having trouble with your counts? Please call Cott at (800)662-9225, option 1. Thanks.**



**Cott Vending Inc.**

The Leader in Premium Retailer Brand Beverage Innovation

**Bottles or cans are jamming in the column. What should I do? Try the steps listed below, and then call us at (800)662-9225, option 1, with the results.**

***\*\*When clearing a product jam, be prepared to catch the bottle or can if it falls from the bottom of the column and down the product chute.\*\****

Unplug the machine and empty as much product as possible from the jammed column. Plug the machine in again to perform the rest of this procedure.

Open the outer and then the inner door of the machine. Locate the coin mechanism. To the right and up slightly, you will see a square metal box. That is where the control board is located.

Near the bottom of that metal box you will see two round holes. The large round hole to the right is where the mode button is located. Insert your finger into the larger hole and press the mode button one time.

After pressing the mode button, you will need to look at the digital display on the front of the machine, *while carefully keeping the doors of the vendor opened*. The display will show "**Error**" once you have pressed the mode button.

*Push the top product selection button twice and you will see the word "tEst" appear on the display. Press the second selection button once, and then press the top selection button once, and the display will show "JoG". Press the second selection button one time, and the digital display will show "CO 1".*

If you now *press selection button one (the top button)*, you will see the display change to "**CO 2**". Every time you press the top selection button, the display will change, representing the next column in series. Remember, the columns inside of the machine are numbered from right to left.

Once you have the jammed column number on the display, *press selection button two*. The display will show "**For**" (forward). *Press the top selection button*, and the display will show "**rEU**" (reverse).

Now *press the second selection button* to jog or move the mechanism in the bottom of the jammed column (enough to remove the package that was stuck). NOTE: If you press that second selection button briefly, the mechanism will move only slightly, but if you hold that second selection button or press it multiple times, the mechanism will move much more, freeing up more space to remove the jammed package.

**Trouble clearing a jammed column? Please call Cott at (800)662-9225, option 1. Thanks.**



**Cott Vending Inc.**

The Leader in Premium Retailer Brand Beverage Innovation

**How do I test vend a column without inserting coins? Try the steps listed below, and then call us at (800)662-9225, option 1, with the results.**



***\*\*When test vending, be prepared to catch the bottle or can.\*\****

Open the outer and then the inner door of the machine. Locate the coin mechanism. To the right and up slightly, you will see a square metal box. That is where the control board is located.

Near the bottom of that metal box you will see two round holes. The large round hole to the right is where the mode button is located. Insert your finger into the larger hole and press the mode button one time.

After pressing the mode button, you will need to look at the digital display on the front of the machine, *while carefully keeping the doors of the vendor opened*. The display will show “**Error**” once you have pressed the mode button.

*Push the top product selection button twice* and you will see the word “**tEst**” appear on the display. *Press the second selection button twice*. The display will show “**CO 1**”.

If you now press *selection button one (the top button)*, you will see the display change to “**CO 2**”. Every time you press the top selection button, the display will change, representing the next column in series. Remember, the columns inside of the machine are numbered from right to left.

Once the column number that you wish to test has been displayed, *press selection button two again*. The column you selected should dispense a product. **\*\*Please be prepared to catch that product, or it may hit the floor or ground and damage the package.**

To end the test, press the mode button, and the display will return to the current product sale price. Remember, if your machine sells different products at different prices, the display will show “00” rather than showing just one of the prices.

**Trouble test vending a column without inserting money? Please call Cott at (800)662-9225, option 1. Thanks.**



Cott Vending Inc.

The Leader in Premium Retailer Brand Beverage Innovation

**My machine is dispensing more than one product at a time. What should I do? Follow these steps below and call us at (800)662-9225, option 1, with the results.**



If the machine is vending more than one product from one or more columns, you may need to adjust the “product steps.” The product steps are one of the ways the machine controls how many bottles or cans are to be dispensed from the columns.

There are divider walls between each column where the product is loaded into the stacks. You will need to look at the *bottom* side of each of those column dividers (so this will require you to be on level with the large triangular chute where the product slides down before coming out the door of the machine).

*On the right side of each column, at the very bottom of the divider walls, you will see black plastic clips with thumb tabs. The tabs are part of the product steps.*

Make sure these clips or tabs are pushed in the correct position (see diagram below). The tabs must be pushed *all the way back for tall product*, like water bottles. The tabs must be pushed *all the way forward for shorter product*, like the twelve ounce soda pop cans. Vend with coins, and call Cott at (800)662-9225, option 1, if you continue to have problems.

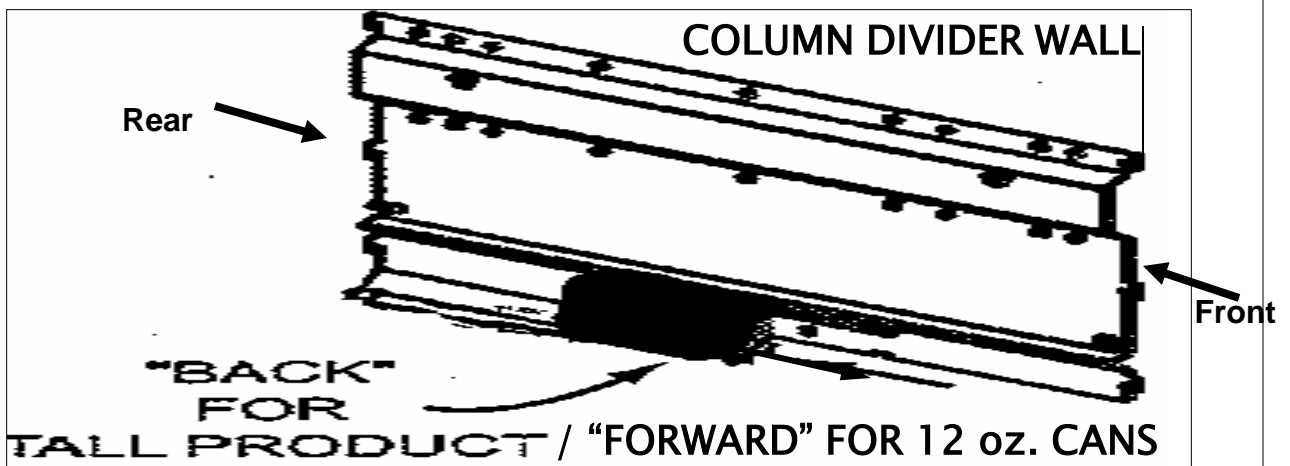



**Cott Vending Inc.**

The Leader in Premium Retailer Brand Beverage Innovation

The vending machine is not cooling.  
What can I check?



1. Look behind the triangular can/bottle chute. Is the evaporator coil covered with thick frost or ice? **Yes/No**  
If yes, defrost the machine by unplugging. It may take a full day to thaw completely.\*  
*If you cannot reach the plug at the wall, your machine has a main power plug in the lower left corner, inside of the machine with the door open. **Please do not touch the fuse near the power plug inside of the machine. Never use a sharp object to chip ice away!***
2. Is the soft, rubber, door seal on the inner door obstructed, torn, or flattened? **Yes/No**
3. Make sure there is no standing water in the machine. There is a drain hole on the shelf under the can/bottle chute, near the back right corner of the machine (approximately seven inches from the back and six inches from the right inside wall of the cabinet). If the drain becomes clogged, the water will accumulate on the shelf. The excess moisture can cause the coils to build up ice. Poke a pencil or straw through the drain hole to clear it. Be sure to remove the object that you use to clear the drain. \*Standing water can lead to ice on the cold coils as described in #1 above. Is the drain clear? **Yes/No**
5. Check for air flow in the cabinet. There is a fan directly behind the cooling coils. If the fan is not working the coil will build up a lot of frost. The fan pulls air through the coils which will create suction at the front of the coils. Hold the door switch in for a few seconds. (The door switch is a plunger style switch located on the front, left side of the shelf that runs the entire width of the cabinet under the large triangular product chute. The shelf is what separates the bottom, warm section of the cabinet from the top, cold section.) See if a piece of paper pulls to the front of the coils. This will verify sufficient airflow.
  - Paper pulls on the evaporator coil (behind the can/bottle chute). **Yes/No**
  - Paper pulls on the condenser coil (bottom right and looks like a radiator). **Yes/No** *Please note, this set of coils in the bottom of the machine, which resembles a car radiator or the coil on an air conditioner, is behind a metal grate. Paper will need to be inserted behind that grate but in front of the "fins," in order to do a proper check of the air flow. For that reason, a half or quarter sized sheet of paper may work best. Also, the fins should be brushed with a stiff broom or plastic bristle brush every thirty days. Please do not use a wire brush, as it can harm the copper coolant lines imbedded between the fins. If the store has a shop vac, that might be an even better alternative to a brush, because it can be inserted between gaps in the grate which covers the fins.*
6. Look at the small port door (where the cans/bottles come out of the main door) and see if it closes properly after each vend? **Yes/No** Is that port door cracked? **Yes/No**
7. Is the machine at least four inches from the wall behind it? **Yes/No** The machine has to vent warm air out the back of the unit.

**Please call Cott Vending at (800)662-9225, option 1, with these answers. Thanks.**